



Ottawa 6x4 DOT/EPA Certified Standard Specifications

6 X 4 YARD TRACTOR

STANDARD FEATURES

- Cummins ISB6.7 200 HP (2010) Clean Idle Certified @2300 RPM 520 lb/ft torque @1600 RPM with primary fuel filter/water separation with WIF sensor
- Allison 3000RDS Transmission (6 speed) with synthetic transmission fluid
- Front Axle: Meritor FF-961, 12,000 lb
- Rear Axle: Meritor RT-40-145 7.17:1 Ridewell dynalastic Suspension, 48,000 lb. rating
- 146" Wheelbase with "L" reinforcement
- Fifth wheel: Holland FW-35, 70,000 lb plate rating
- Fifth wheel lift cylinders: 5" diameter, 60,000 lb rating
- Tires 11R22.5 Steel belted radials 14PR
- Wheels 22.5" X 8.25" 10 bolt 285 mm BC hub piloted, steel disc
- Horizontal exhaust system with vertical stack and heat shield
- Air cleaner, frontal inlet - 11" replaceable element and underhood restriction indicator
- Back-up light, stop and turn signals
- Mud-flaps rear spring loaded
- Mud-flaps behind steer axle
- Battery box with step 16" width
- Cab side vent (riveted)
- Drive shaft Spicer 1710 series
- Approximate Vehicle Weight 18,000 lbs.
- GCWR 81,000 Lbs
- Maximum Road Speed 45 MPH / 72.4 KPH
- MaxiMizer fuel reduction system

TRAILER EQUIPMENT

- Two (2) color coded, coiled air lines with glad hand receivers, 7 wire female receptacle at rear of cab, 7 wire coiled trailer light cable

STEERING

- Gearbox type integral power steering with mechanical back up
- Constant running PTO/pump with priority steering circuit

CAB FEATURES

- Cab air ride, 3-point mount suspension
- Cab with raised roof: 50" X 65" X 68" welded steel and driver's side door which has a full length piano hinge and an aluminum sliding rear door
- Cab insulation, for thermal protection and noise abatement
- Cab tilt: Electric 45° with 90° tilt capability Platform, rear of cab
- Air Ride Seat with isolator
- Seat belt with 2-point mount
- Tinted glass all windows
- Solar gray laminated glass behind driver
- 40,000 BTU fresh air heater/defroster
- West coast 16" X 7" mirrors
- See through sun visor
- ICC light package

Cab gauges:

Volt meter, oil pressure, water temperature, fuel level, air pressure, speedometer, diesel exhaust fluid and 5-digit hour-meter

Cab controls:

Accelerator, tractor/trailer brakes, gear selector, fifth wheel elevation, steering wheel 18" soft touch, dash light controls, turn signals, electric horn, heater defroster, electric windshield washer, electric windshield wiper control, door locks, headlights, side and front clearance lights, inter axle lock, rear flood light upper right side, 5th wheel unlatch

WARNING DEVICES

- Low air pressure light and alarm
- Transmission protection warning light
- Headlight hi-beam indicator
- Electric backup alarm
- Engine protection warning system
 - High coolant temp
 - Low oil pressure
 - Low coolant level
 - Water in fuel

Ottawa 6x4 DOT/EPA Certified

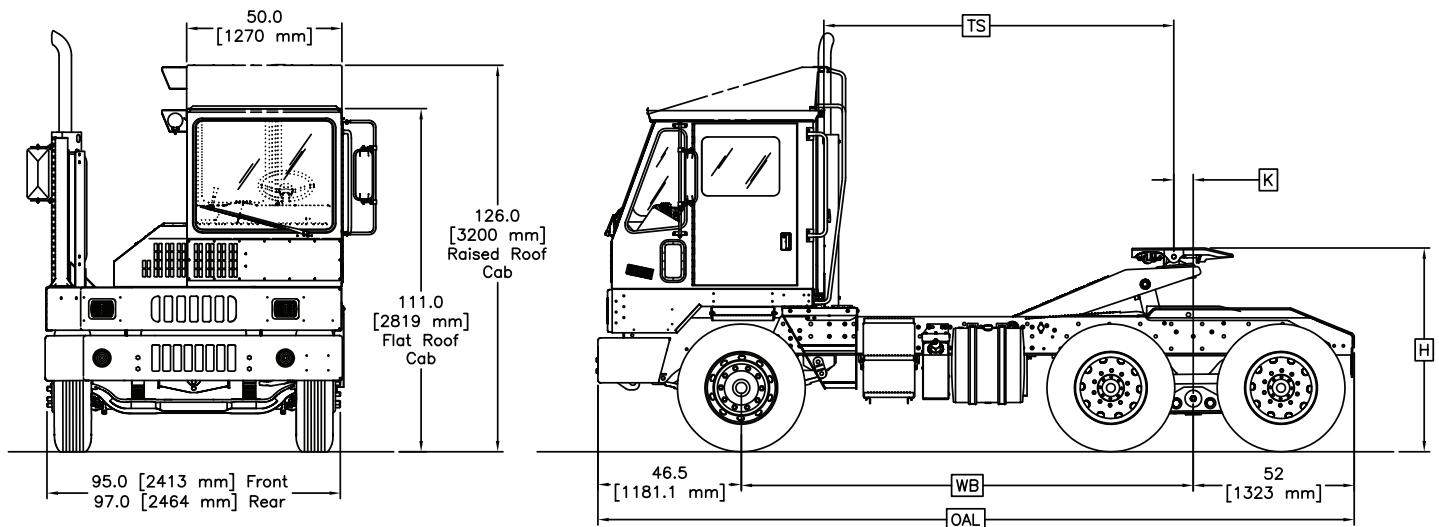

		BOOM POSITION	
WB	DIM	UP	DOWN
146" (3708.4 mm)	TS	113 (2874 mm)	118 (2989 mm)
	K	6.0 (153 mm)	1.5 (38 mm)
	H	66 (1664 mm)	48.0 (1211 mm)
	OAL	244 (6207 mm)	

HYDRAULIC SYSTEM

- 16 gallon tank with sight glass
- 10 GPM pump
- 5" hydraulic lift cylinders
- Hydraulic system with "O" Ring fittings
- Boom lift 17"
- Wet Spine PTO

BRAKES

- Split Brake system
- FMVSS 121 Brake system with ABS
- Front: "S" Cam type 16.5" x 5" air actuated
- Rear: "S" Cam type 16.5" x 7" air actuated
- Automatic slack adjusters front and rear

FRAME FEATURES

- Welded 80,000 psi steel with 12" x 3 3/8" X 3/8" formed channel 43.25" wide frame with "L" frame reinforcement (3,878,000 in/lb RBM)
- 55° tapered deck curbside with reinforced removable bumper
- 40-gallon frame mounted round fuel tank, streetside
- Integral front and rear tow eyes
- 5 gallon DEF tank

PNEUMATIC SYSTEM

- 18.7 CFM Wabco compressor with 4 tank air reservoir system total capacity 6518 cu. in
- Color-coded air lines

ELECTRICAL SYSTEM

- 12 Volt neg. ground with circuit breakers, 130-amp minimum charge alternator, color coded wiring in separate removable harness, 12-volt starter with positive engagement, two (2) 12-volt low maintenance batteries, cab dome light.

PAINT FINISH

- Cab: Full immersion, multi-stage, "E" coat primer. Baked on acrylic top coat - white PPG - SAC71166A
- Chassis: shot blasted, epoxy primer, polyurethane top coat - bare chassis, 2nd polyurethane top coat during assembly
- Wheels: Paint "E" coat white
- Rubberized undercoating under cab and deck
- Grab handles, steps and platforms painted safety yellow

